

VXIbus
UP TO 12 CHANNELS of 3-WIRE LVDT/RVDT STIMULUS
ON-BOARD PROGRAMMABLE EXCITATION SUPPLY

FEATURES

- Programmable output voltage
- On-board optional programmable excitation
- Continuous background BIT testing
- Extensive diagnostics
- Wideband 360 Hz to 20 kHz
- Optional Ratiometric or Self leveling conversion
- Message based C size VXI card for with Mate CIIL VISA Plug-and-Play Driver Library available.
- Dynamic address configuration
- VXIbus data rate of 2 megabytes/sec
- Data is processed within 100 μ s
- Occupies only a single slot
- No adjustments or trimming



DESCRIPTION

This single slot, message based VXIbus instrument can be populated with either one or two daughtercards. Each daughtercard can provide up to eight (8) LVDT/RVDT 3-wire with wraparound self test and an optional programmable excitation supply. Currently, a total of sixteen (12) 3-wire channels and an excitation supply can be provided within one single slot enclosure (see part number). An optional feature permits programming each output for either ratiometric or self-leveling (fixed) mode. In the ratiometric mode, the output voltage will vary directly/proportionately with the excitation voltage. In the self-leveling (or fixed) mode, the output voltage is programmed and remains constant regardless of excitation voltage. Standard/default is ratiometric. This card is a uniquely versatile instrument because each excitation input and output voltage is programmable. In addition, each channel may be programmed to be controlled by an external DC voltage (see part number).

SPECIFICATIONS:

APPLIES TO EACH 8 CHANNEL DAUGHTERCARD

Number of Outputs:	Eight. (maximum – see part number)
Output voltage (Va and Vb):	0-24 Vrms $\pm 1\%$ at no load. Transformer isolated. Output voltage is programmable as % of full scale (FS) range
Output phasing:	Either $V_a + V_b = K$ or $V_a - V_b = K$, programmable
Accuracy:	$V_a + V_b = K \pm 1\%$ or $V_a - V_b = K \pm 1\%$
Resolution:	16 bits (.001526% FS range)
Linearity:	$\pm 0.05\%$ FS range (at 20 KHz, $\pm 0.2\%$ FS range)
Load:	3.5 ma. max. Outputs are short circuit protected.
Regulation:	$\pm 1\%$ 10K ohms to no load $\pm 2\%$ with a 4K ohm load
Excitation:	2.0 to 28 Vrms; Programmable and Transformer isolated.
Excitation Current:	1.5 mA max. per channel @ 360 Hz.
Excitation Frequency:	360 Hz to 20 KHz. Output voltage will not vary more than $\pm 1\%$ over frequency.
Phase Shift:	$\pm 1.5^\circ$ max
Ratiometric/Self-leveling:	In the Ratiometric mode, the output voltage will vary directly with the excitation voltage. In the Self-leveling mode, the programmed output voltage will remain constant even though the excitation varies. The Self-Leveling mode is optional. See part number.
Optional DC input:	Differential. ± 10 VDC or ± 5 VDC. See part number. (System GND referenced).
Output Control:	The Va and Vb outputs are controllable by either Internal or External commands. In the External Mode , the Va and Vb outputs are controlled by an external analog signal. This differential input signal of ± 10 VDC or ± 5 VDC (see part number) corresponds to 0 to 100% position.
Latency:	Va to Vb latency: The differential latency between Va and Vb output changes as a function of position change will be less than 500 nsec. External Position to Output Latency: The time between an analog position input voltage change and the corresponding Va & Vb output change will not exceed 200 μ s. Internal Position to Output Latency: The time between a position change commanded over the VXI bus for any given channel and the corresponding Va and Vb outputs changing will not exceed 8 msec.
VXIbus Data rate:	2 megabytes/second
Temperature, operating:	-10°C to +65°C
Temperature, storage:	-40°C to +85°C
Relative humidity:	to 93% RH non-condensing
Shock:	Designed to meet 15G, 11 ms
Vibration:	Designed to meet MIL-T-28800C for class V equipment.
Altitude, operating:	10,000 feet
Altitude, non operating:	40,000 feet
Power Requirements:	± 12 VDC at 600 mA +5 VDC at 500 mA
Size:	"C" size (13.386" x 9.187") with 1.2" pitch. (349mm x 234 mm) with 30 mm pitch
Weight:	4.3 lbs. (1.95 Kg)
Calibration intervals:	No calibration is required.
Connectors:	Mating connectors are not supplied.

Excitation Supply

Optional. (See part number).

Voltage: 2.0-28 Vrms programmable (resolution 0.1 Vrms); Accuracy $\pm 2\%$.Frequency: 400 Hz to 10 KHz $\pm 1\%$ with 1 Hz resolution.

Regulation: 10% max. No load to full load.

Output power: 5 VA max. at 40° min. inductive.

Power Requirements

	$\pm 12\text{Vdc}$	+5Vdc
Motherboard	N/A	660 mA
Daughter-card (handles up to four output modules)	12 mA	380 mA
Output Module (two channels)	140 mA	12 mA
Output LOADED – (adds per channel)	1.6 mA per 1 mA (load)	N/A
Excitation Module	N/A	110 mA
Excitation LOADED – (adds per channel)	N/A	275 mA per 1 VA (load)

PRINCIPAL OF OPERATION (LVDT)

Typically the primary is excited by an AC source, causing a magnetic flux to be generated within the transducer. Voltages are induced in the two secondaries, with the magnitude varying with the position of the core. Usually, the secondaries are connected in series opposition, causing a net output voltage of zero when the core is at the electrical center. When the core is displaced in either direction from center the voltage increases linearly either in phase or out of phase with the excitation depending on the direction

Output Configuration

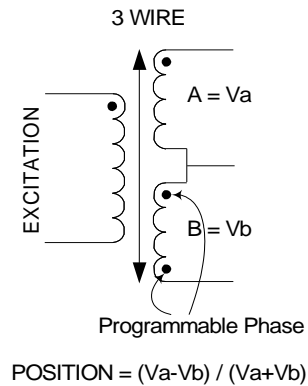

LVDT Coil Voltage vs. Position

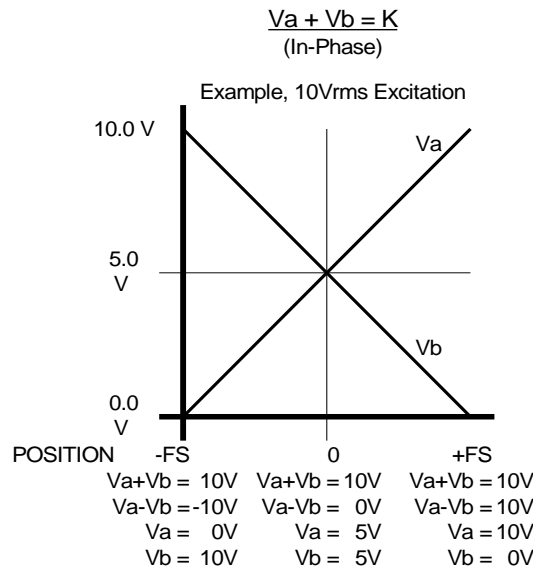

CARD ADDRESS

Address Dip Switches 1 can each be configured for logical addresses 1 to 255, where OFF=1 and ON=0. LSB is position 1.

Decimal	Logical Address 128 (Default)	Logical Address 33 (Example)
1 (LSB)	SW1, position 1=0 (ON)	SW1, position 1=1 (OFF)
2	SW1, position 2=0 (ON)	SW1, position 2=0 (ON)
4	SW1, position 3=0 (ON)	SW1, position 3=0 (ON)
8	SW1, position 4=0 (ON)	SW1, position 4=0 (ON)
16	SW1, position 5=0 (ON)	SW1, position 5=0 (ON)
32	SW1, position 6=0 (ON)	SW1, position 6=1 (OFF)
64	SW1, position 7=0 (ON)	SW1, position 7=0 (ON)
128 (MSB)	SW1, position 8=1 (OFF)	SW1, position 8=0 (ON)

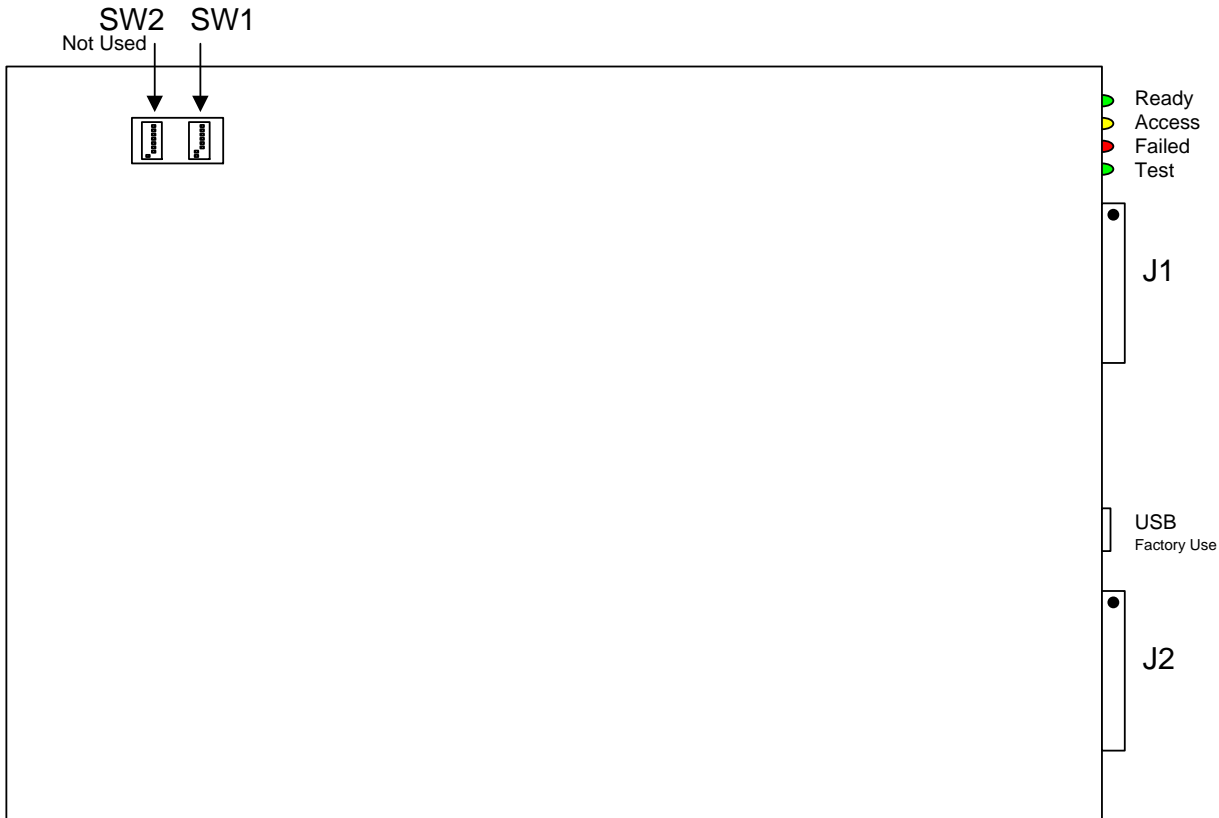

65DL2 Bottom View

FRONT PANEL STATUS INDICATORS

Status Indicators	Function
READY	Indicates that unit is ready to accept commands
ACCESS	Indicator is lit when VXI bus controller sends or reads a message or status.
FAILED	Lights on power-up and goes out after unit has passes system self-test. Stays lit if device has failed Self-Test or Calibration. Indicator will also light in response to Controller SYSFAIL output
TEST	Illuminates while Internal Self-Test is running, flashes while in Calibration.

PROGRAMMING

NOTE: To support output phase programming, native command

IN_PHASE [TRUE/FALSE]

where TRUE configures output for $V_a - V_b = K$ and FALSE configures output for $V_a + V_b = K$ was added.

The following sections define MATE/CIIIL and SCPI formats with supporting examples.

Function Block Diagram

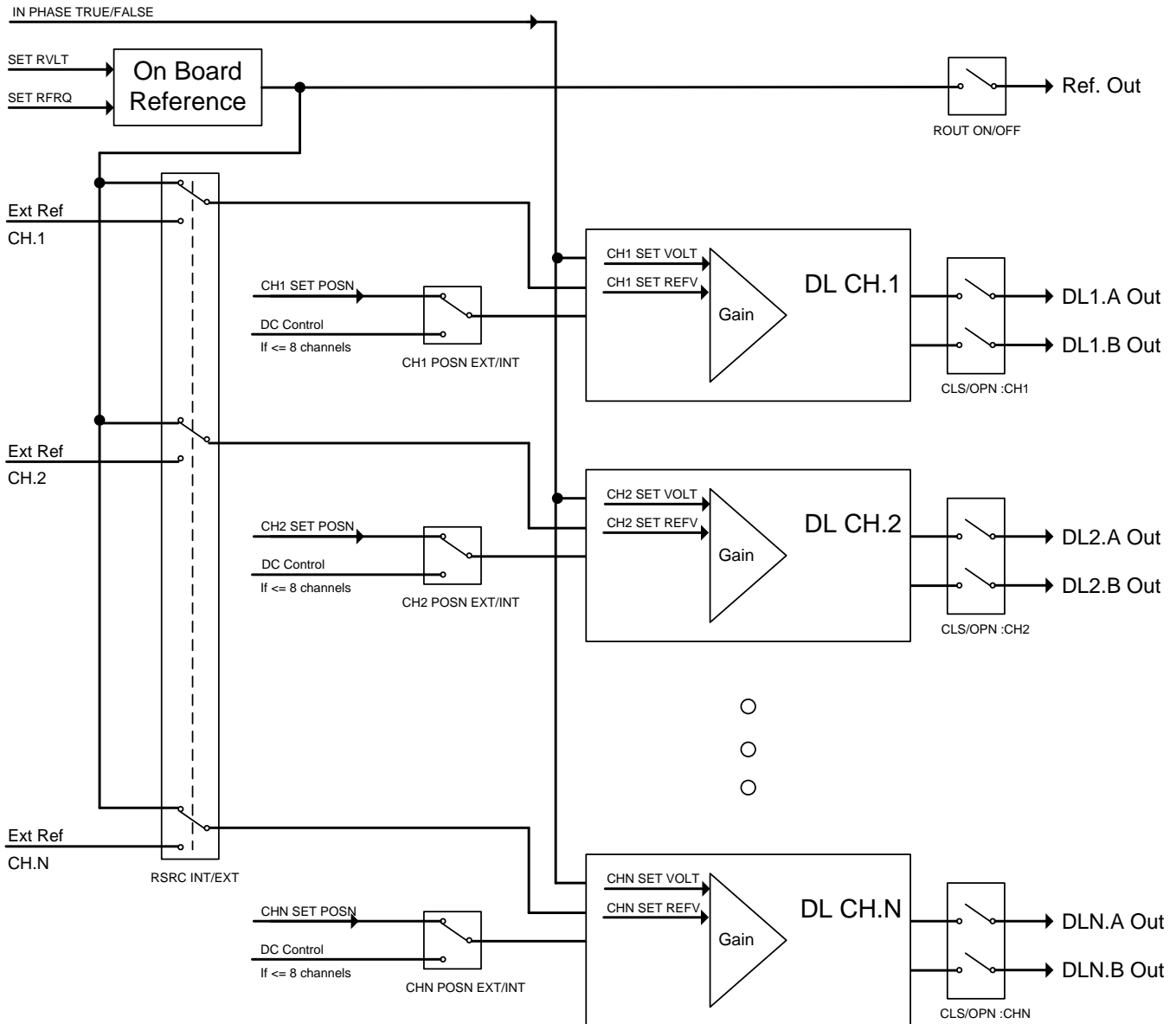

MATE / CONTROL INTERMEDIATE INTERFACE LANGUAGE (CIIL) SYNTAX

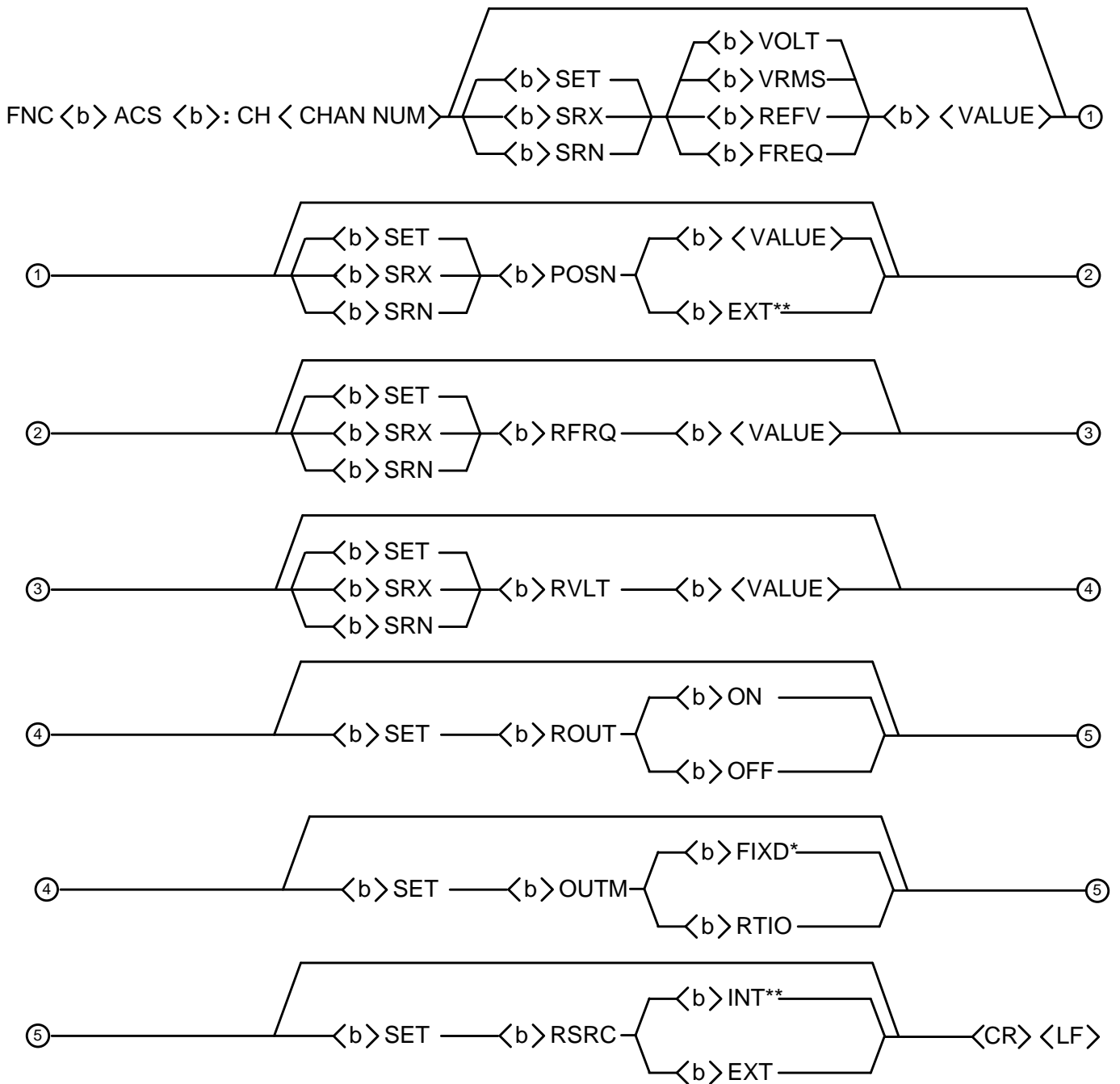

Note: * SETOUTMFIXD sets to Self Leveling Output. RTIO is for Ratiometric output.

** SETRSRCINT sets ALL channels to internal reference source.
Reference sources for individual channels cannot be set individually.

CLS : CH <CHAN NUM>————<CR> <LF>
 OPN : CH <CHAN NUM>————<CR> <LF>
 RST ACS : CH <CHAN NUM>————<CR> <LF>
 STA <CR> <LF>
 IST <CR> <LF>
 CNF <CR> <LF>

RESPONSE TO STA

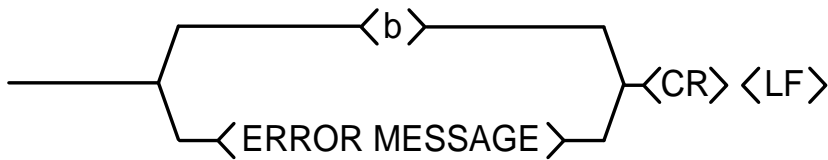

CH <CHAN NUM> where CHAN NUM = 0 TO n OR 00 TO n
 (where “n” equal maximum configured channels)

POWER ON or RESET Command Default Values

RELAY(S)	OPEN
VOLTAGE	= 0.0 Volts
POSITION	= 50 %
RSRC	= EXT
REFV	= 10 Vrms

Error Reporting

1. VXIbus Commands

Errors indicated by (ERR*) bit in response register
 Errors reported in response to error query command

2. Operational or syntax errors

Error messages sent in response to serial message (STA)

Response to (IST, CNF)

Open Isolation Relays
 Input sequence of voltages to each channel from internal source
 Perform measurements
 Compared with stored values
 Max Self-test time = 60 seconds

Data Field

ASCII FLOATING POINT	±.DDDDDDDDDE±DD MANTISSA = 1 to 14 Digits EXPONENT = 1 or 2 Digits
ASCII DECIMAL	±DDDD.DDDDD 1 to 14 Digits Decimal point at any position
ASCII INTEGER	±DDDDDDDD 1 to 15 Digits
ASCII SCIENTIFIC	±D.DDDDDDDDE±DD MANTISSA = 1 to 14 Digits EXPONENT = 1 or 2 Digits

EXPONENT Range Limited -09 to +09

± Sign is Optional
No Sign = +

LVDT/RVDT Command Summary

FNC	(SET, SRX, SRN) set up instrument
CLS	Close input path
OPN	open input path
RST	reset channel
STA	report status
CNF	perform confidence test
IST	perform built in test
IN_PHASE	<i>Native command added to support output phase programming where TRUE configures output for $V_a - V_b = K$ and FALSE configures output for $V_a + V_b = K$</i>

Notation

< >	field boundaries
	ASCII blank
<CR> <LF>	ASCII carriage return followed by ASCII line feed
<NOUN>	ACS
<SET CODE>	SET SRX <i>positive limit</i> SRN <i>negative limit</i>
<MCHAR>	VOLT VRMS REFV FREQ POSN RFRQ <i>Added by NAI for Reference Programming</i> RVLT <i>Added by NAI for Reference Programming</i> ROUT <i>Added by NAI for Reference Programming</i> RSRC <i>Added by NAI for Reference Programming</i> WHEN SET TO INTERNAL, DC INPUT IS DISABLED. REFERENCE SOURCES TO INDIVIDUAL CHANNELS CANNOT BE SET INDIVIDUALLY.
<CHAN NUM>	0 to 7, or 00 to 07
<VALUE>	See FNC Command Format
<MODIFIER>	VOLT or VRMS <i>Output Voltage</i> REFV <i>Reference Voltage</i> FREQ <i>Frequency</i> POSN <i>Output Position, Center = 50%</i>

Command Format

FNC instrument set-up

FNC<NOUN>:CH <CHAN NUM> [<SETCODE><MODIFIER><VALUE>]***<CR><LF>

<NOUN> ACS (error msg) #1

<CHAN NUM> 0 to n, (where n = number of channels configured)
or 00 to n (error msg) #4

<SETCODE> SRX *Maximum value*
SET
SRN *Minimum value* (error msg) #5

<MODIFIER> VOLT or VRMS *Voltage Span*
REFV *Expected Ref voltage input*
FREQ *No effect*
POSN *Output Position* (error msg) #7

<VALUE> REFV *2 to 10 Vrms*
FREQ *360 to 20,000 Hz*
POSN *0 to 100%,
or EXT (External)*

CLS close isolation relay

CLS:CH <CHAN NUM> <CR><LF>

OPN open isolation relay

OPN:CH <CHAN NUM> <CR><LF>

RST reset

RSTACS:CH <CHAN NUM> <CR><LF>

STA report status

STA <CR><LF>

Response

<CR><LF> Normal

<error msg><CR><LF> Error

IST internal self test

IST <CR><LF>

CNF confidence

CNF<CR><LF> *Confidence test requires up to 60 seconds before results are available*

*** Optional field or structure field repeated as often as required

Error Messages

1. "F07ACSnn (MOD): COMMAND ERROR";
2. "F07ACSnn (MOD): NOUN ERROR";
3. "F07ACSnn (MOD): MISSING CR";
4. "F07ACSnn (MOD): CHANNEL NUMBER ERROR";
5. "F07ACSnn (MOD): SET CODE ERROR";
6. "F07ACSnn (MOD): MCHAR ERROR";
7. "F07ACSnn (MOD): MODIFIER ERROR";
8. "F07ACSnn (MOD): VALUE ERROR";
9. "F07ACSnn (MOD): XPONENT RANGE ERROR";
10. "F07ACSnn (MOD): NO SPACE";
11. "F07ACSnn (MOD): BIT FAIL";
12. "F07ACSnn (MOD): MESSAGE OVERFLOW";
13. "F07ACSnn (MOD): MESSAGE SYNTAX ERROR";

Where nn is the channel number

Programming Examples

Provided below are two programming examples. The 65DL2 is programmed using command strings of ASCII text, or command messages. These messages are displayed in quotes for convenience.

Example to set channel 0 for full 10 Vrms reference external, 10 Volts Line-Line and Full Scale (FS) position (100%)

SET RSRC EXT sets ALL channels to external references sources.

Reference sources to individual channels cannot be set individually.

"FNC ACS :CH0 SET RSRC EXT"

"FNC ACS :CH0 SET REFV 10 SET VOLT 10 SET POSN 100"

"CLS :CH0"

"STA"

Read Device

" "

Set Reference to External

Program Output Configuration

Close Channel 0

Send Status Request

Expected Response is blank, or ASCII 32

Example to set channel 0 for 10 Vrms reference internal, 10 Volts Line-Line, 400Hz, and FS position (100%)

When setting Reference Source to Internal, DC Input control is disable or ignored.

SET RSRC INT sets ALL channels to internal references sources.

Reference sources to individual channels cannot be set individually.

"FNC ACS :CH0 SET RSRC INT"

"FNC ACS :CH0 SET RVLT 10 SET RFRQ 400 SET POSN 100"

"FNC ACS :CH0 SET ROUT ON"

"CLS :CH0"

"STA"

Read Device

" "

Set Reference to Internal

Program Output Configuration

Turn Reference ON

Close Channel 0

Send Status Request

Expected Response is blank, or ASCII 32

Example to set channel 0 for 10 Vrms reference external, 10 Volts Line-Line and position to DC Input

SET RSRC EXT sets ALL channels to external references sources.

Reference sources to individual channels cannot be set individually.

"FNC ACS :CH0 SET RSRC EXT"

"FNC ACS :CH0 SET REFV 10 SET VOLT 10 SET POSN EXT"

"CLS :CH0"

"STA"

Read Device

" "

Set Reference to External

Program Output Configuration, Ext DC Input

Close Channel 0

Send Status Request

Expected Response is blank, or ASCII 32

User sets external DC Source to 10 volts (Option B)

Example to initiate and query confidence test

"CNF"

Wait or implement parallel task

Read Device

" "

Initiate Confidence Test

*Confidence Test requires 60 second to complete
Poll DATA OUT READY Bit.*

Expected Response is blank, or ASCII 32

VERIFICATION TEST SET-UP

This unit does not require field calibration because it is self calibrating. Use the following setup, or similar, to verify performance.

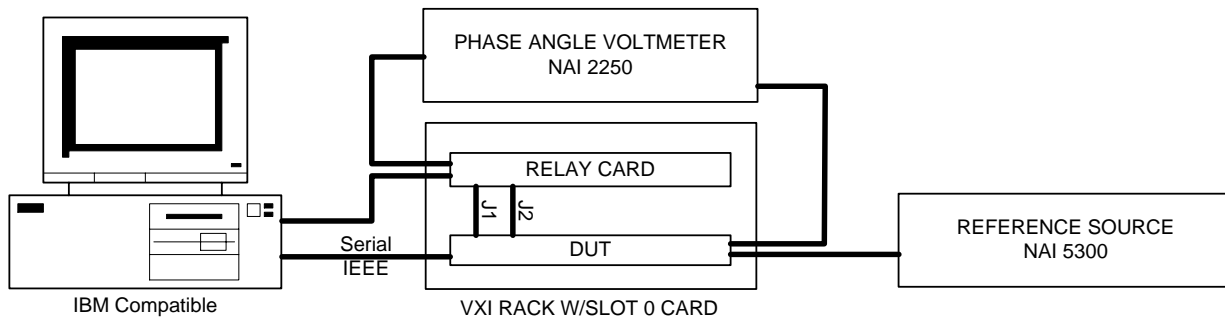

CONNECTORS:

J1, *J2: HDL78SLB Mate: HDT78PD with strain relief 745082-1

**** J3: DB25P; Mate: DB25S;**

J1			
Pin	Description	Pin	Description
3	Va	11	Va
4	Common Ch.0	12	Common Ch.4
42	Vb	50	Vb
22	Excitation HI	30	Excitation HI
61	Excitation Lo	69	Excitation Lo
5	Va	13	Va
6	Common Ch.1	14	Common Ch.5
44	Vb	52	Vb
24	Excitation HI	32	Excitation HI
63	Excitation Lo	71	Excitation Lo
7	Va	15	Va
8	Common Ch.2	16	Common Ch.6
46	Vb	54	Vb
26	Excitation HI	34	Excitation HI
65	Excitation Lo	73	Excitation Lo
9	Va	17	Va
10	Common Ch.3	18	Common Ch.7
48	Vb	56	Vb
28	Excitation HI	36	Excitation HI
67	Excitation Lo	75	Excitation Lo
20	Internal Exc.Hi Out	59	Internal Exc.Lo Out

J2			
Pin	Description	Pin	Description
3	Va	11	Va
4	Common Ch.0	12	Common Ch.4
42	Vb	50	Vb
22	Excitation HI	30	Excitation HI
61	Excitation Lo	69	Excitation Lo
5	Va	13	Va
6	Common Ch.1	14	Common Ch.5
44	Vb	52	Vb
24	Excitation HI	32	Excitation HI
63	Excitation Lo	71	Excitation Lo
7	Va	15	Va
8	Common Ch.2	16	Common Ch.6
46	Vb	54	Vb
26	Excitation HI	34	Excitation HI
65	Excitation Lo	73	Excitation Lo
9	Va	17	Va
10	Common Ch.3	18	Common Ch.7
48	Vb	56	Vb
28	Excitation HI	36	Excitation HI
67	Excitation Lo	75	Excitation Lo
20	Internal Exc. Hi Out	59	Internal Exc. Lo Out

J3	
Pin	Description
1	DC Hi Ch. 0
2	DC Lo Ch. 0
3	DC Hi Ch. 1
4	DC Lo Ch. 1
5	DC Hi Ch. 2
6	DC Lo Ch. 2
7	DC Hi Ch. 3
8	DC Lo Ch. 3
9	DC Hi Ch. 4
10	DC Lo Ch. 4
11	DC Hi Ch. 5
12	DC Lo Ch. 5
22	DC Hi Ch. 6
23	DC Lo Ch. 6
24	DC Hi Ch. 7
25	DC Lo Ch. 7

***J2 is only supplied when 12 channels are specified**

**** J3 is only supplied when external DC is specified (For 8 channel units only)**

For 12 channels units, 8 channels are on J1 and 4 channels are on J2 (channels 9 thru 12 are referenced on J2 as respective Ch0 thru Ch3).

DO NOT CONNECT TO ANY UNDESIGNATED PINS.

PART NUMBER DESIGNATION

65DL2 - **XX X 0 M X X X**

TOTAL NUMBER OF CHANNELS

08 = Eight channels
12 = Twelve channels (contact factory)

EXTERNAL DC CONTROL

C = None
B = ± 10 VDC ^{*1}
A = ± 5 VDC ^{*1}

3-WIRE OUTPUT

PROGRAMMING

M = Mate CIIL

MODULATION

0 = None

PROGRAMMABLE OUTPUT MODE

0 = Standard ratiometric
P = Programmable ratiometric or self leveling outputs.

EXCITATION SUPPLY

0 = None
R = One 5 VA Excitation supply

Notes:

^{*1} Option available on 8 channel configuration only

APPENDIX A – CE

INFORMATION FOR UNITS SOLD WITHIN THE EUROPEAN UNION

GENERAL

Information contained within the following paragraphs supplements and in some cases supersedes information contained throughout this Manual. Where there is a conflict between information contained in these paragraphs and information contained elsewhere in the manual, these paragraphs take precedence for units sold within the European Union.

CLASSIFICATION

The 65 series model is defined for CATEGORY I installation and usage in a POLLUTION DEGREE 1 environment.

INSTALLATION

The 65 series model is designed for installation in a VXI standard card cage. Only the front panel is accessible to the OPERATOR during normal usage.

SAFETY GROUNDING

For safety from electrical shock and fire, the mounting surface (rear) of the front panel must be kept free of contamination and the unit must be mounted in a VXI card cage with the mounting screws properly tightened. The VXI card cage frame must be properly connected to a safety earth ground.

IMPROPER USAGE

If the equipment is installed or used in a manner not specified safety may be impaired. The equipment may not be used in CATEGORY II, III or IV installation.

MAINTENANCE

The OPERATOR only has access to the exterior of the unit. All maintenance, including any procedures that require removal of covers, must be referred to qualified maintenance personnel

TECHNICAL ASSISTANCE

Contact your local Sales Representative for any technical assistance. Alternatively, contact the Factory at:

North Atlantic Industries
110 Wilbur Place
Bohemia, NY 11716 USA

Telephone: (631) 567-1100
Fax: (631) 567-1823
Web: www.naii.com



DECLARATION OF CONFORMITY

We **NORTH ATLANTIC INDUSTRIES, INC.**
110 WILBUR PLACE,
BOHEMIA, NY 11716-2416

declare under our sole responsibility that the following products

65 SERIES

To which this declaration relates is in conformity with the following standard(s) or other normative document(s):

EMISSIONS PER EN 61326:1997/A1:1998/A2:2001

CISPR16:1999	Class A, Conducted Emissions
CISPR16:1999	Class A, Radiated Emissions
IEC 61000-3-2:2000	Harmonics
IEC 61000-3-3:1994	Flicker

IMMUNITY PER EN 61326:1997/A1:1998/A2:2001

IEC 1000-4-2:1995	Electrostatic Discharge
IEC 1000-4-3:1995	Radiated Immunity
IEC 1000-4-4:1995	EFT/Burst, Power and I/O Leads
IEC 1000-4-5:1995	Surge Immunity, Power Leads
IEC 1000-4-6:1996	Conducted Immunity, Power and I/O Leads
IEC 1000-4-11:1994	Voltage Dips and Interrupts

SAFETY PER EN 61010-1:2001

IEC 61010-1:2001	Safety
------------------	--------

Following the provisions of COUNCIL DIRECTIVE 89/336/EEC
2006/95/EC

Place Bohemia NY, USA

(original on file)

(Signature)

Date 5/27/05

Rob Carillo
(Full Name)
Quality Manager
(Position)

REVISION PAGE

Revision	Description of Change	Engineer	Date
4.0	Initial Release	GS	5/05/03
4.1	Appends Output Voltage spec from ± 34 to $0-24V_{rms} \pm 1\%$ at no load. Added Card Address. Added Programming section to define 8 or 16 channel addressing.	GS	5/19/3
4.2	Adds Programming Examples. Adds Assy Dwgs. Adds RSRC INT.	GS	6/3/3
5.0	Added two excitation supplies for 16 ch. Design; various clarifications	FH	12/17/03
5.1	Clarified P/N designation	FH	12/18/03
6.0	native command IN_PHASE [TRUE/FALSE] added where TRUE configures output for $V_a - V_b = K$ and FALSE configures output for $V_a + V_b = K$	GS	7/29/04
6.1	Adds 12 channels	GS	12/7/4
6.2	Adds Function Block Diagram	GS	3/2/5
6.3	Update Function Block Diagram	GS	3/3/5
6.4	Adds OUTM for self leveling vs ratiometric output.	GS	7/12/5
6.5	CHANGED ADDRESS	DD	05/07/07
A	Updated power requirements / Added Appendix A - CE addendum	AS	05/15/08
A1	Agile-format / Added self-leveling mode description / Removed SW2 addressing references	AS	05/19/08
A2	Release to Agile	AS	05/29/08
A3	Clarified available part number configuration option(s) / limited to 12 CH max.	AS	09/11/12